

ORG

Semi-Automatic Bulk Butter Filling Machine

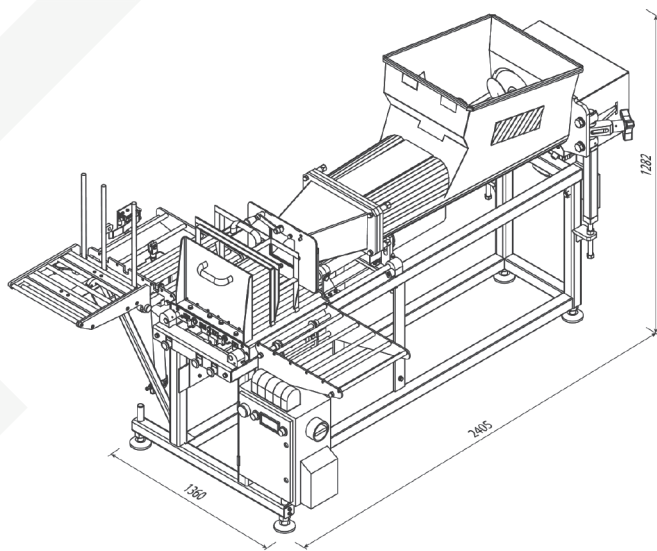



Bulk butter filling machine **ORG** is a semi-automatic filling machine designed for butter filling into pre-made boxes (bag-in-box).

ORG main features

- Semi-automatic filling machine for the bulk butter filling into pre-made boxes (carton or plastic);
- Pneumatic box turn-back system;
- Replaceable dosing head for second box size (optional);
- Pneumatic set of automation: cutter and box pusher (optional manual cutter);
- Digital scales for weight control (optional);
- Auxiliary transporter (optional).

TECHNICAL DATA

Machine type	semi-automatic
Applicable products	butter
Max. capacity, cartons/h	up to 150 *depends on operator's skills
Product input temperature °C	+9...+16
Feeding	hopper with 2 horizontal augers
Dosing type	extruder volumetric
Weight of box, kg	5-10, 15-20-25
Inner size of the box ¹ , mm	5 kg – 240 x 200 x 130 10 kg – 240 x 200 x 263 15 kg – 380 x 253 x 187 20 kg – 380 x 253 x 250 25 kg – 380 x 253 x 305
Control	PLC and control panel with buttons and switches
Accuracy, %	2,5
Productivity regulation	incrementally
Washing mode	manual
Compressed air supply, MPa (bar)	0,5...0,6 (5...6)
Compressed air consumption, m ³ /min	0,22
Rated power input, kVA	4,5
Voltage, V	230/400 ± 10%
Frequency, Hz	50/60
Electricity supply	3 phase
Approx. machine size (L x W x H), mm	2405 x 1360 x 1282 *without scales 4057 x 1762 x 1394 *with scales
Approx. machine weight, kg	440 *without scales 545 *with scales

¹ Box size calculated to the butter density of 915 kg/m³