

ARG

Ice-Cream Filling and Wrapping Machine

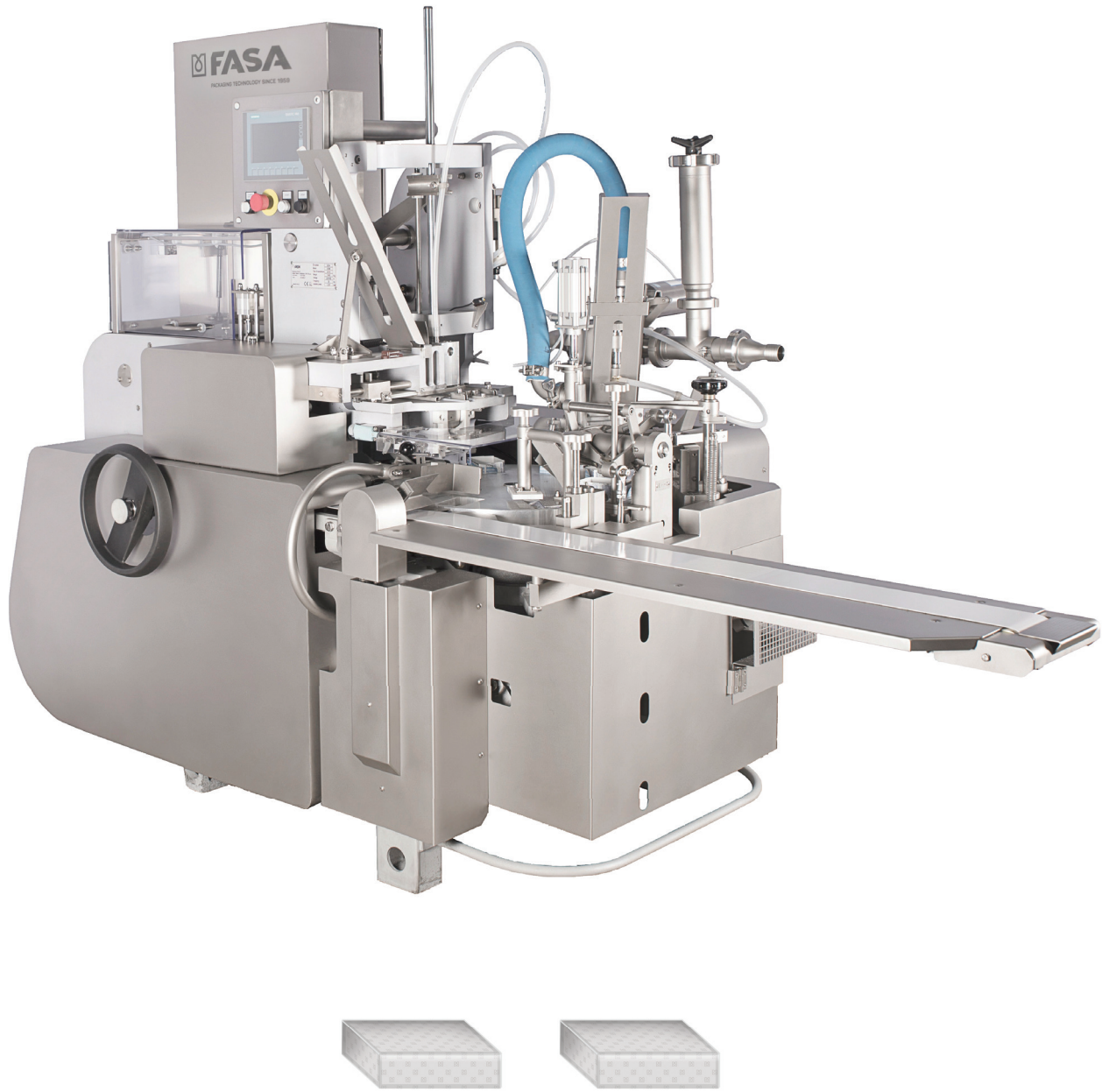

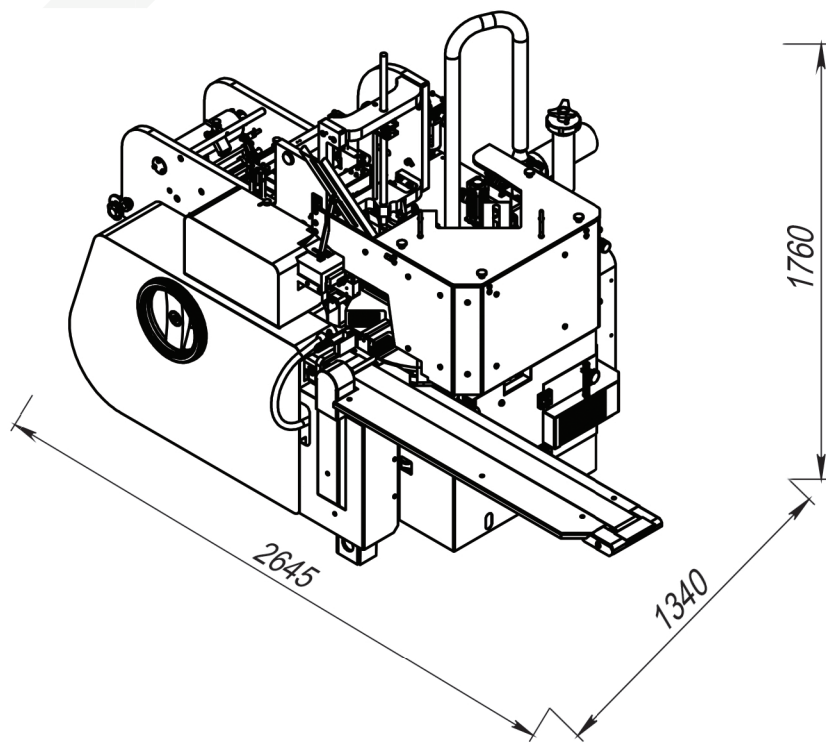

Ice cream filling and wrapping machine **ARG** is for sandwich ice-cream packaging with or without waffles to bricks.

ARG main features

- Packing ice-cream with or without waffles into consumer size portions.
- Shapes of package: rectangular.
- Stainless steel dosing unit.
- Machine body covers from stainless steel.
- Machine safety covers.
- Sensor for foil tracking.
- Foil centering device with photocell.
- UV lamp.
- Possible printers (optional): Ink jet, Thermoprinter or Cold emboss coding unit.

TECHNICAL DATA

Machine type	rotary type, continuous operation
Applicable product	ice-cream
Max capacity, packs/min	up to 50
Dose mass, ml	135-240
Product input temperature, °C	-4...-6
Feeding	direct feeding through pipes from the freezer
Dosing type	volumetric
Packaging material	laminated aluminum foil
Folding type of package	bottom folding
Inner reel (core) diameter, mm	70
Outer reel diameter, mm	up to 400
Material thickness, mm	0,05-0,08
Control	PLC and HMI with Touch Screen
Accuracy, %	± 6
Productivity regulation	incrementally
Lubrication system	central (optional)
Washing mode	manual
Compressed air supply, MPa (bar)	0,4...0,6 (4...6)
Compressed air consumption, m ³ /min	0,013
Rated power input, kVA	4,5
Voltage, V	230/400 ±10%
Frequency, Hz	50/60
Electricity supply	3 phase
Approx. machine size (L x W x H), mm	2645 x 1340 x 1760
Approx. machine weight, kg	1450