

AR2T

Curd Filling and Wrapping Machine

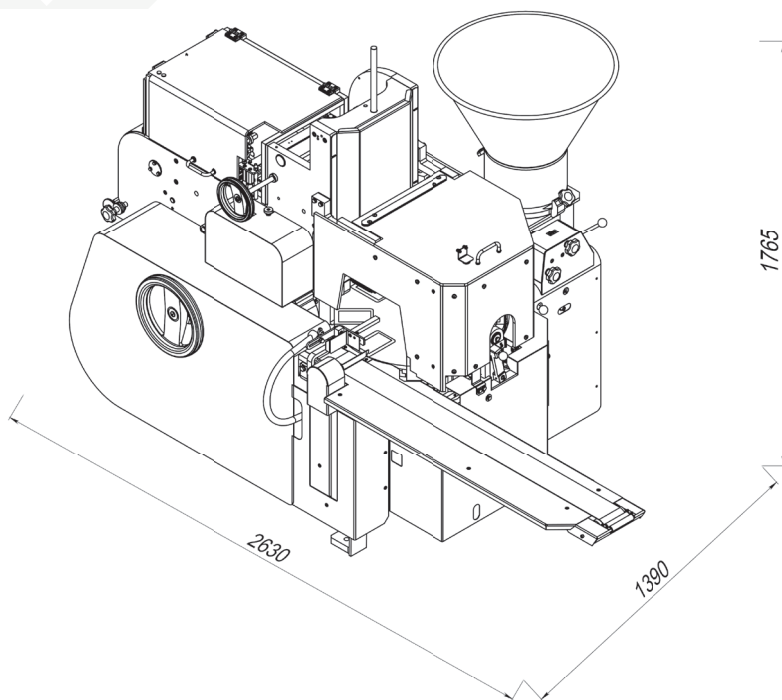



Curd filling and wrapping machine – **AR2T** is designed to fill and wrap curd (tvorog) into aluminum foil or parchment paper. Filling and wrapping machine AR2T could be used in combination with Flow-Pack machine PM.

AR2T main features

- Packing curd into consumer's size portions.
- Possibility to shift between portion weight by changing the height of brick.
- Shapes of package: rectangular.
- Stainless steel dosing unit.
- Stainless steel table with synthetic inserts.
- Machine body covers from stainless steel.
- Machine safety covers.
- Sensor for foil tracking.
- Foil centering device with photocell.
- UV lamp.
- Possible printers (optional): Ink jet, Thermoprinter or Cold emboss coding unit.
- Extended hopper, volume +20l (optional).

TECHNICAL DATA

Machine type	rotary type, continuous operation
Applicable products	curd (tvorog), cottage cheese
Max. capacity, packs/min	up to 70
Dose mass, g	80 – 250
Product input temperature, °C	+6...+15
Feeding	vertical 60l hopper with agitator
Dosing type	volumetric
Packaging materials	laminated aluminum foil, parchment paper, ecoline
Inner reel (core) diameter, mm	70 or 75
Outer reel diameter, mm	up to 400
Material thickness, mm	0,05-0,08
Control	PLC and HMI with Touch Screen
Accuracy, %	1
Productivity regulation	incrementally
Lubrication system	central (optional)
Washing mode	manually
Compressed air supply, MPa (bar)	0,4...0,6 (4...6)
Compressed air consumption, m ³ /min	0,013
Rated power input, kVA	9
Voltage, V	230/400 ± 10%
Frequency, Hz	50/60
Electricity supply	3 phase
Approx. machine size (LxWxH), mm	2630 x 1390 x 1765
Approx. machine weight, kg	1460