

DSU

BUTTER CASE PACKER

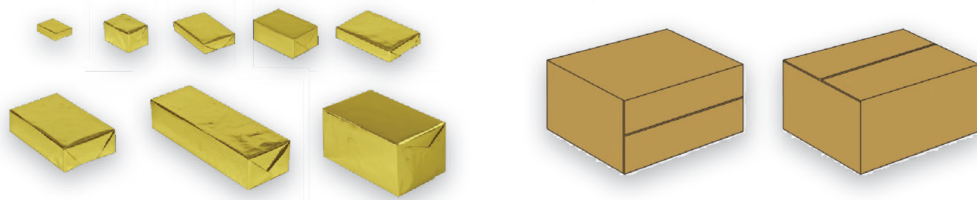

AB FASA
Sporto str. 9, Marijampole, LT-68108, Lithuania
Tel: +370 343 70 481, fax. +370 343 70 469
E-mail: sales@fasa.eu
www.fasa.eu

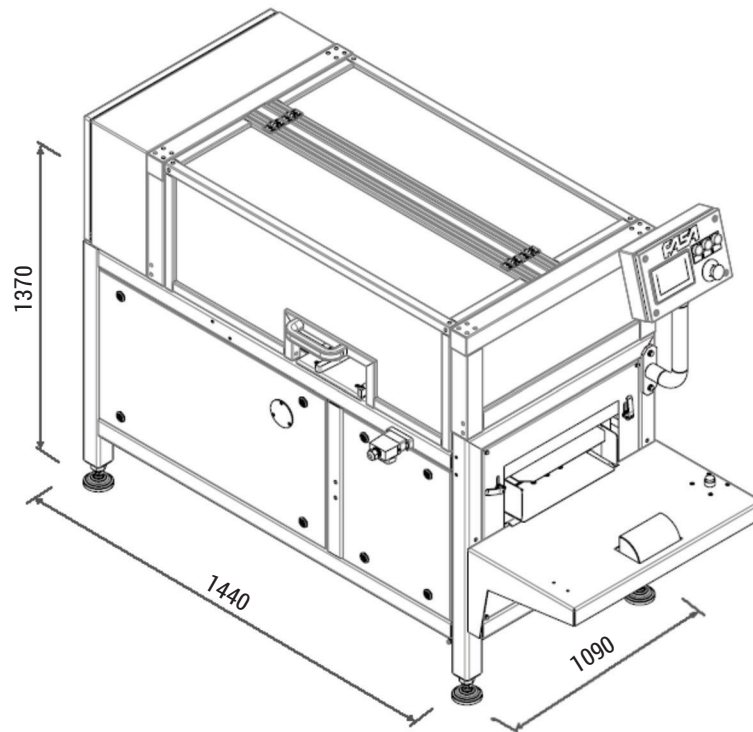

DSU is a semi-automatic cartoning machine used for grouping and stacking of butter bricks packed with ARM or other filling and wrapping machines. It serves as exceptionally reliable and cost-effective end of the line solution.

Simple, user-friendly control panel with function keys, robust construction, easy maintenance and access to all serviceable parts makes DSU consistently attractive. Box feeding through the top or through the side options available.

| TECHNICAL DATA | |
|--|--|
| Machine type | semi-automatic |
| Output, bricks/min, single line feeding | up to 120* |
| Inner box dimensions, mm | Min 60 x 100 x 20, Max 295 x 395 x 220 |
| Air compression, MPa (kg/cm ²) | 0,58 - 0,63 (5,8 - 6,3) |
| Air consumption, m ³ /min | up to 0,0015 |
| Installed capacity, VA | 800 |
| Voltage, V | 120 – 230 AC |
| Frequency, Hz | 50 - 60 |
| Dimensions (L x W x H), mm | 1440 ** x 1090 x 1370 |
| Approx. weight, kg | 250 |

*200g 100x75x29 mm – 40 bricks in box

**depends of the length of the box

